

Inverse problems and machine learning in medical physics

Robotics in radiation therapy

Dr. Chiara Gianoli

28/1/2025

chiara.gianoli@physik.uni-muenchen.de

The CyberKnife

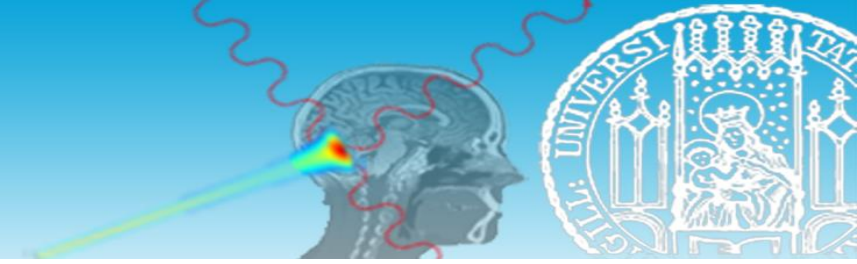

- The CyberKnife is a **radiation delivery system** that features a linear accelerator (*linac*) directly mounted on a **robot** to deliver photons for **radiation therapy**, a fluoroscopic kV X-ray imaging for pre-treatment and intra-treatment **image-guidance** and an optical system for **respiratory motion tracking**
 - 3D conformal radiotherapy (3D-CRT), including intensity modulated radiation therapy (IMRT)
 - Stereotactic radiosurgery (SRS) and stereotactic body radiation therapy (SBRT) treatments

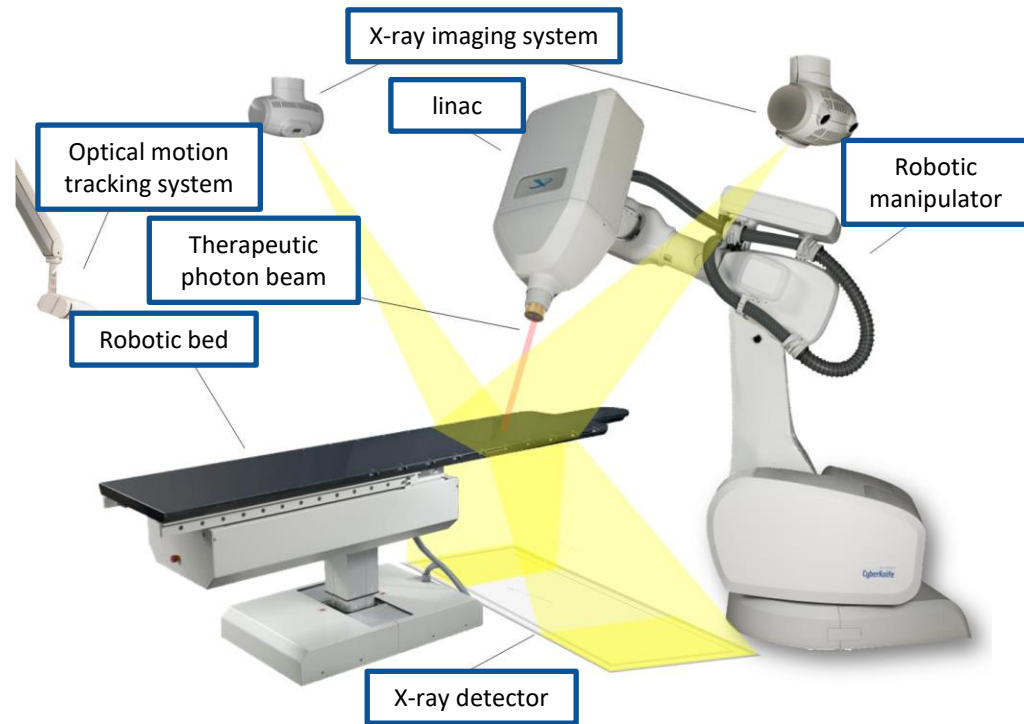

The CyberKnife

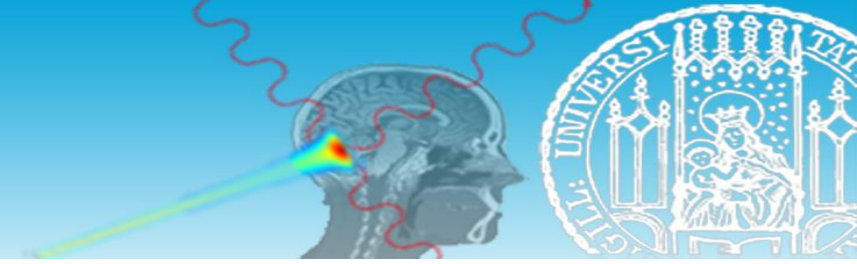

- The beams are delivered from fixed points in space called **nodes**, arranged in spherical (intracranial applications) or ellipsoidal (extracranial applications) configurations
- The combination of nodes and pointing vectors (twelve for each node) provides a set of “elementary beams” to plan the treatment

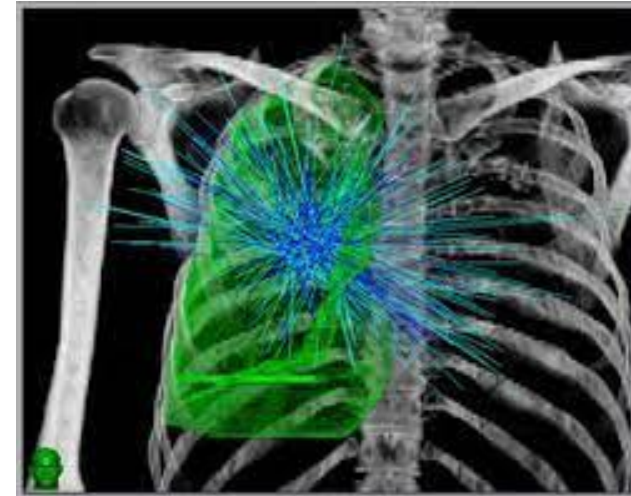
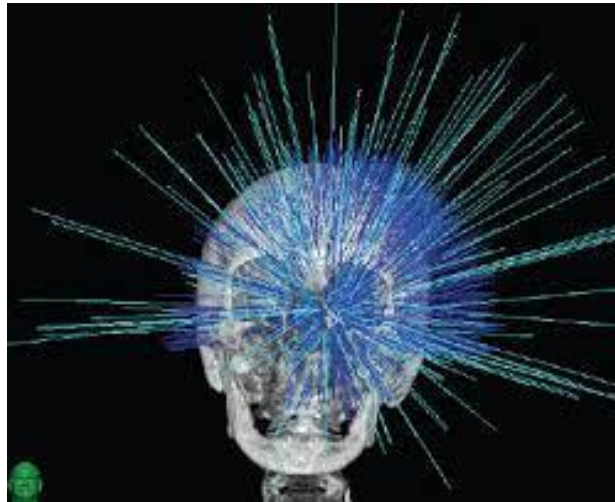

The CyberKnife

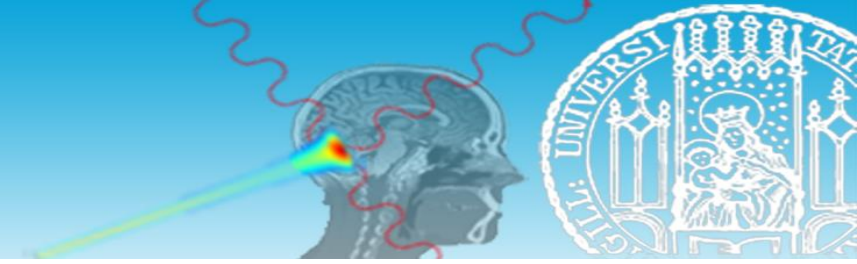

- Prior to the treatment, eight radiographic X-ray images in different breathing phases are compared to the DRRs of the treatment planning X-ray CT image to determine by **triangulation** the transformation to be applied to the 6-DoF **robotic bed** for patient positioning

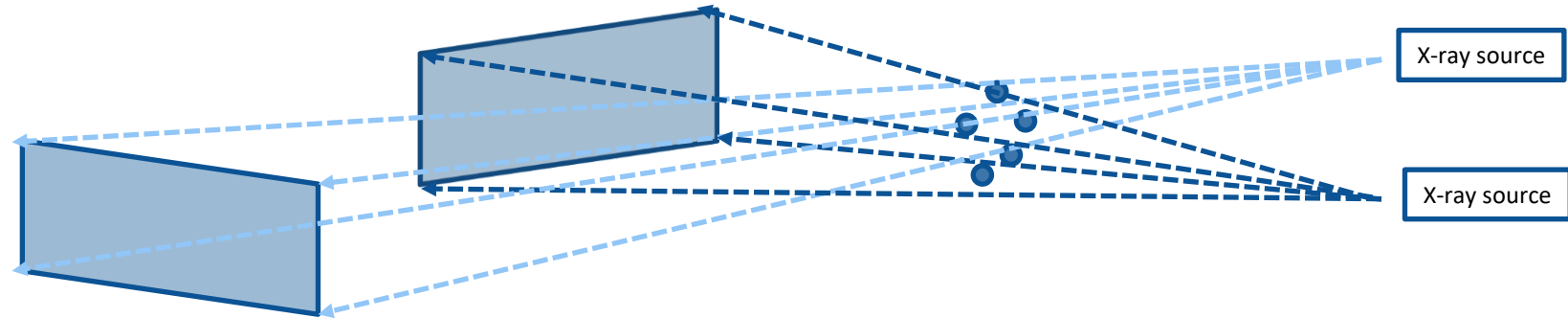

- During the treatment, this transformation is adjusted in real-time by moving the end-effector of the 6-DoF robotic manipulator (*linac*) according to the moving target
- The motion tracking considers:
 - Fiducial-free tumor tracking based on the **optical tracking system** (for external localization at 20–40 Hz) and implanted radio-opaque markers near or inside the tumor based on the **X-ray imaging system** (for internal localization every 30s) thus making use of **external-internal correlation models**
 - The model is constructed in ~30s at the beginning of the treatment and enables **motion prediction** for delay compensation (~ms)



LUDWIG-
MAXIMILIANS-
UNIVERSITÄT
MÜNCHEN

The CyberKnife

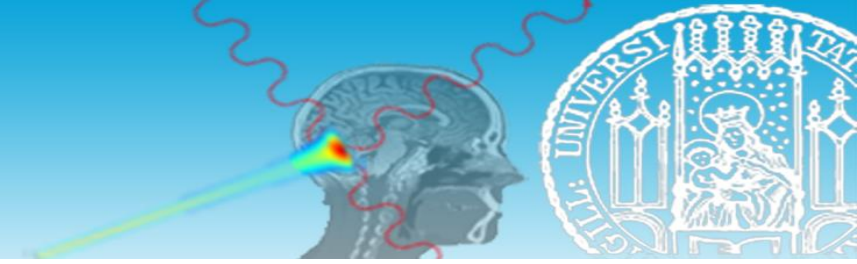

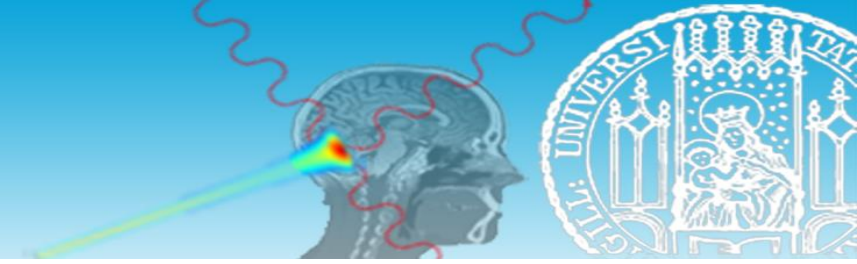

The “forward” kinematics

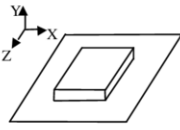
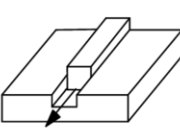
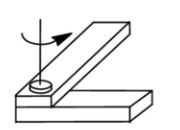

- *First of all, we have to know where the robot is...*
- Kinematics is the science of motion that treats motion without regard to the forces which cause it (i.e., **position, velocity, acceleration...**)
- The forward kinematics problem is about the knowledge of the position of the **end-effector**, given the **kinematic chain** of the mechanical system

- The **kinematic chain** is an assembly of **links** (rigid bodies) connected by **joints** providing **degrees of freedom** (DoF) to the **end-effector**
- the number of DoF of the **end-effector** is determined by the DoF of all the **joints** (i.e., 1-DoF for each **revolute joint**)

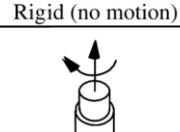
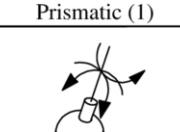
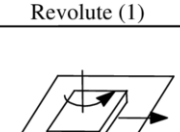
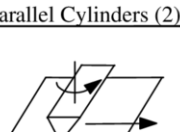
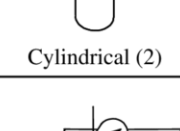
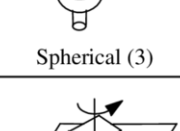
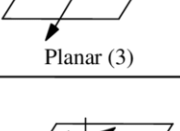
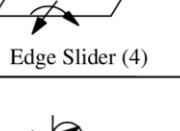
 Rigid (no motion)	 Prismatic (1)	 Revolute (1)	 Parallel Cylinders (2)
 Cylindrical (2)	 Spherical (3)	 Planar (3)	 Edge Slider (4)
 Cylindrical Slider (4)	 Point Slider (5)	 Spherical Slider (5)	 Crossed Cylinders (5)

- The **kinematic chain** is described by the **joint variables** (i.e., the **angles** for the **revolute joints**)

The “forward” kinematics

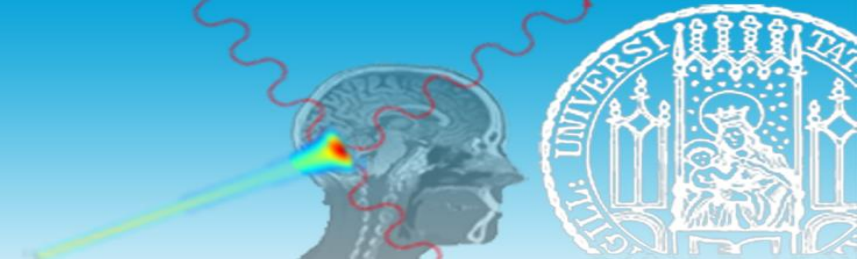

- In order to unequivocally localize the **position** of the **end-effector** in function of the **angles** of the **kinematic chain** (joints and links), the **Denavit–Hartenberg convention** (D-H convention) is commonly adopted
 - The n links are numbered from 0 (the base of the kinematic chain) to $n-1$ (the end-effector)

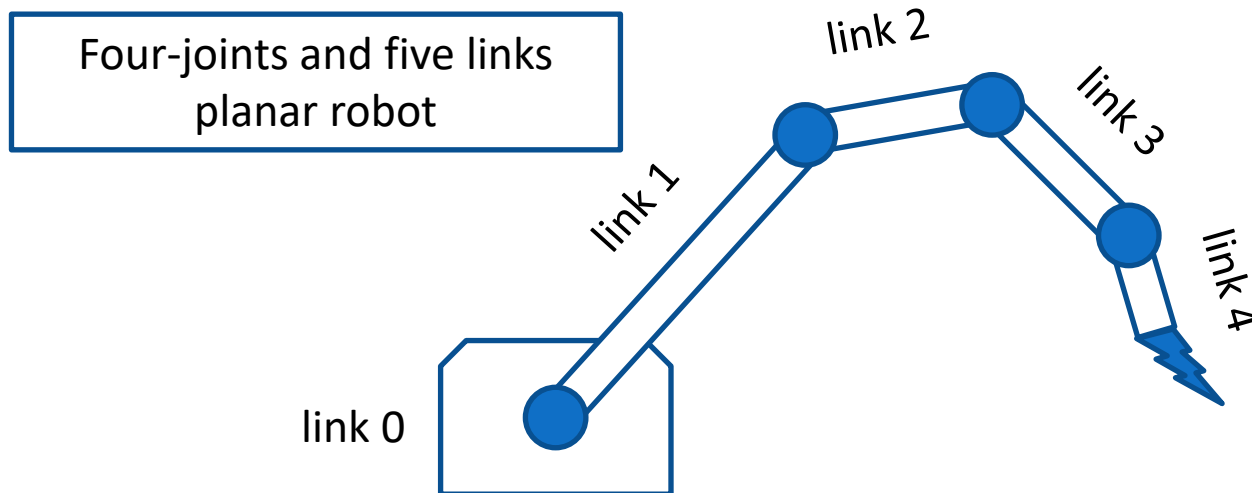

The “forward” kinematics

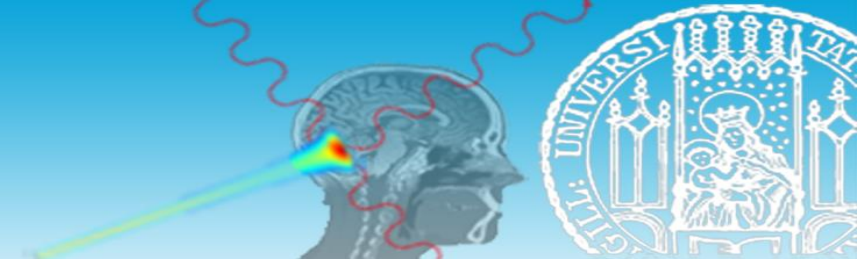

- In order to unequivocally localize the **position** of the **end-effector** in function of the **angles** of the **kinematic chain** (joints and links), the **Denavit–Hartenberg convention** (D-H convention) is commonly adopted
 - The $n-1$ joints are numbered from 1 to $n-1$ so that the joint n connects the link $n-1$ (the base of the kinematic chain) to the link n (the end-effector)

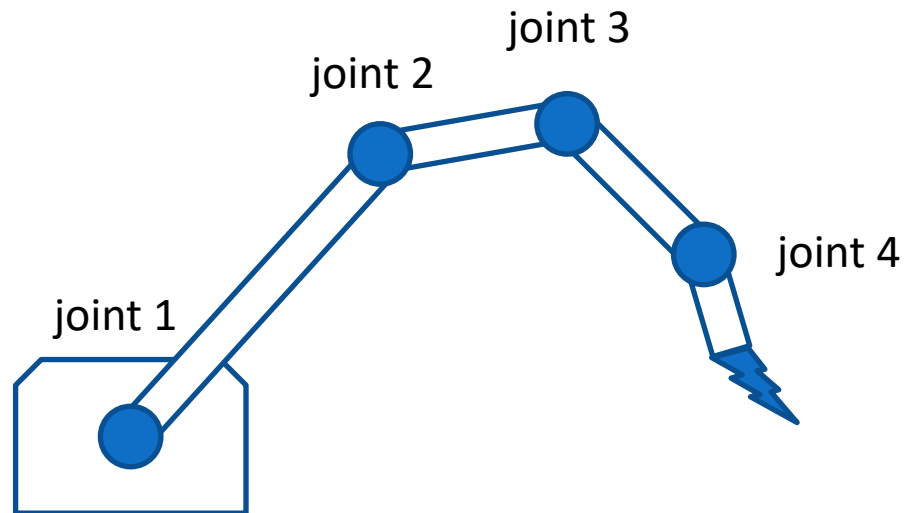

The “forward” kinematics

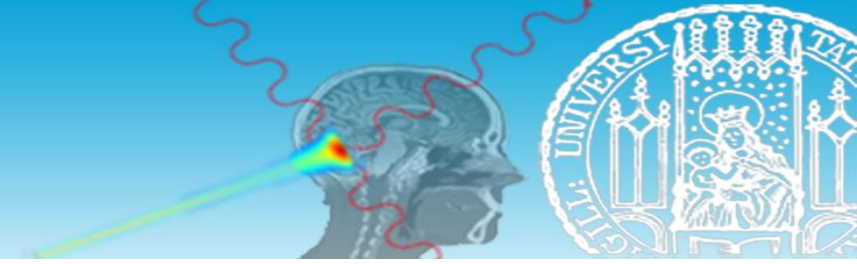

- In order to unequivocally localize the **position** of the **end-effector** in function of the **angles** of the **kinematic chain** (joints and links), the **Denavit–Hartenberg convention** (D-H convention) is commonly adopted
 - A frame n is defined at the joint n

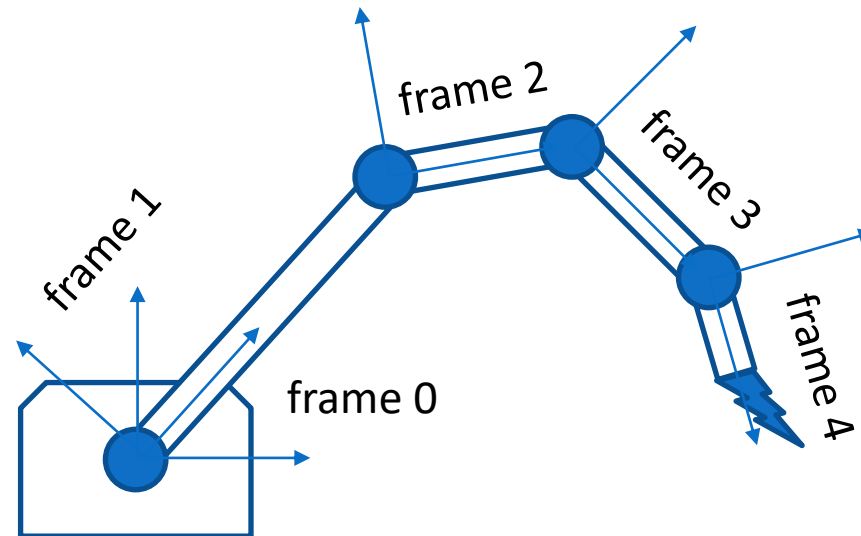

The “forward” kinematics

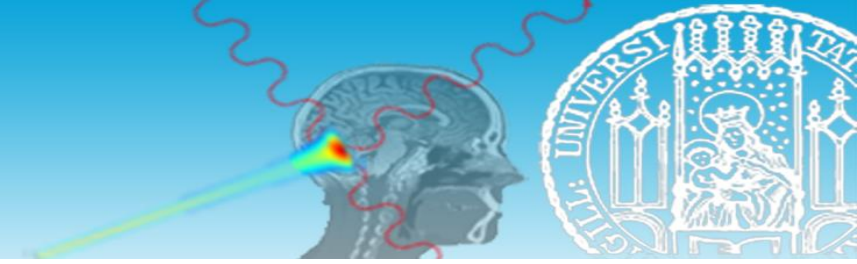

- Z_n is defined as the rotational axis of the revolute joint n
- If Z_n and Z_{n+1} are skew lines, X_n is defined along the common perpendicular of Z_n and Z_{n+1} (the shortest distance between two skew lines is the distance between their intersection points with their common perpendicular), from Z_n to Z_{n+1}
- The origin of the frame n is defined at the intersection point with Z_n
- Y_n is defined according to the right-hand frame

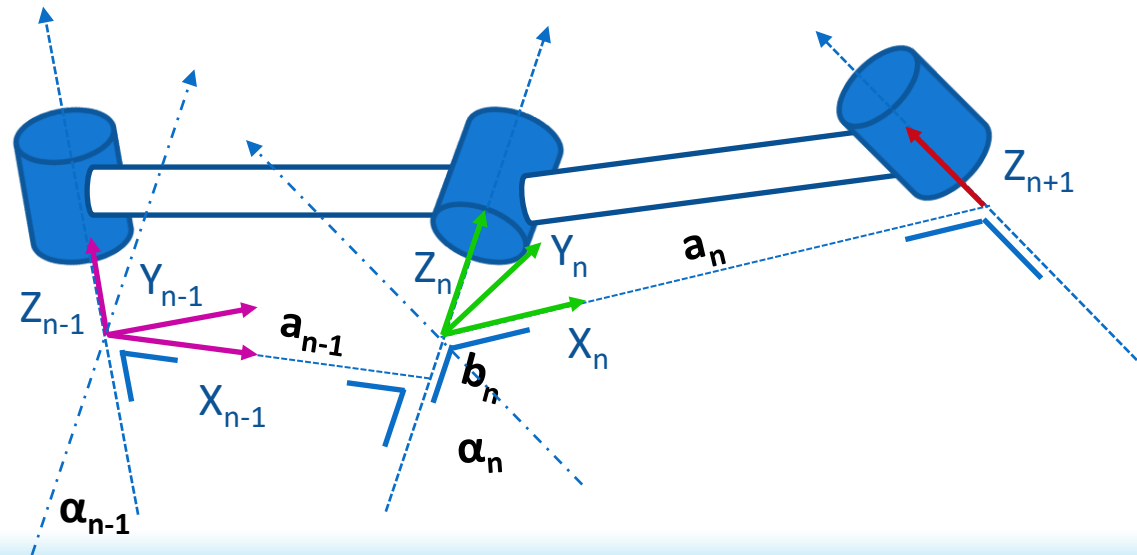

The “forward” kinematics

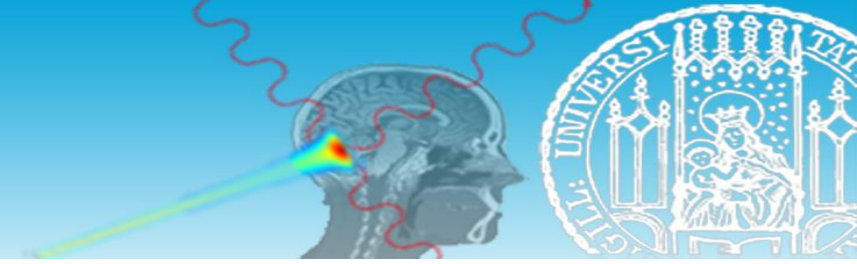

- Z_n is defined as the rotational axis of the revolute joint n
 - If Z_n and Z_{n+1} are **parallel lines** (i.e., planar robot), X_n is defined along the common normal of Z_n and Z_{n+1} , from Z_n to Z_{n+1}
 - The origin of the frame n is set on the joint n
 - Y_n is defined according to the right-hand frame

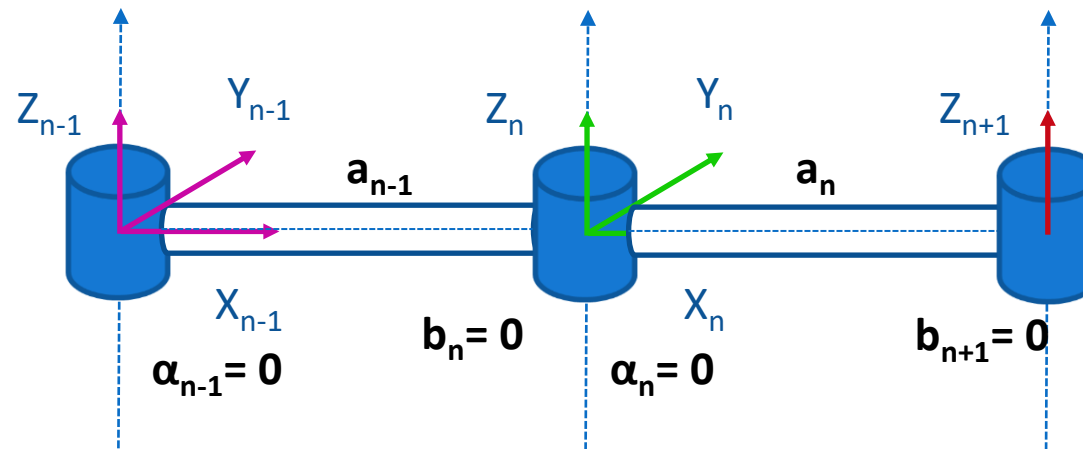

The “forward” kinematics

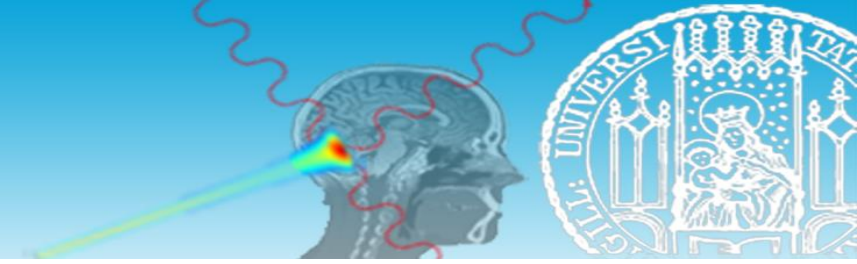

- Z_n is defined as the rotational axis of the revolute joint n
 - If Z_n and Z_{n+1} are intersecting lines, X_n is defined by the vector product between Z_n and Z_{n+1} (i.e., according to the right-hand frame)
 - The origin of the frame n is set on the intersection point
 - Y_n is defined according to the right-hand frame

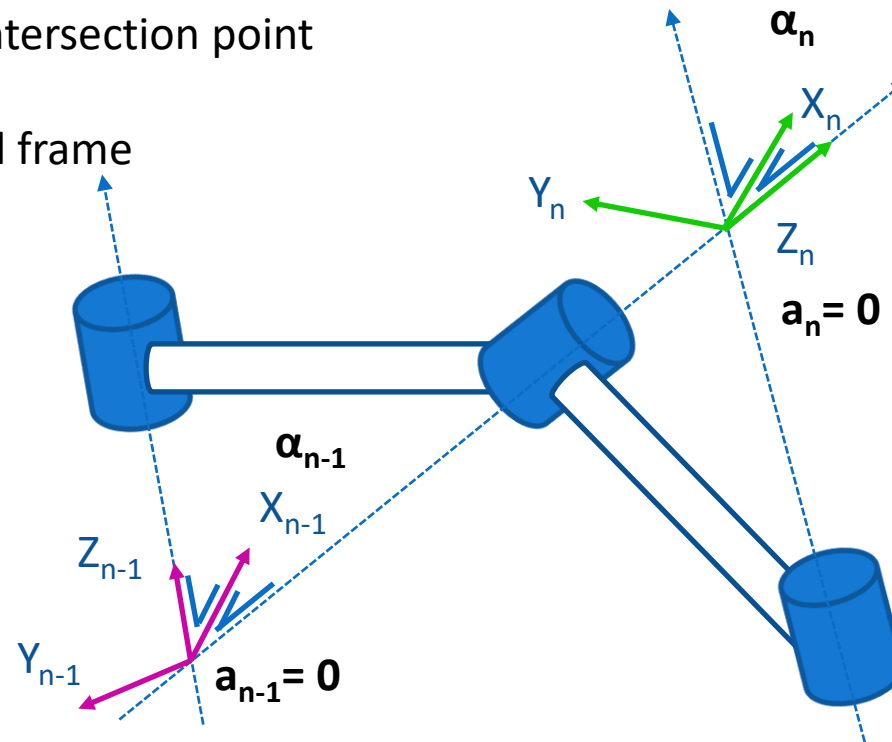

The “forward” kinematics

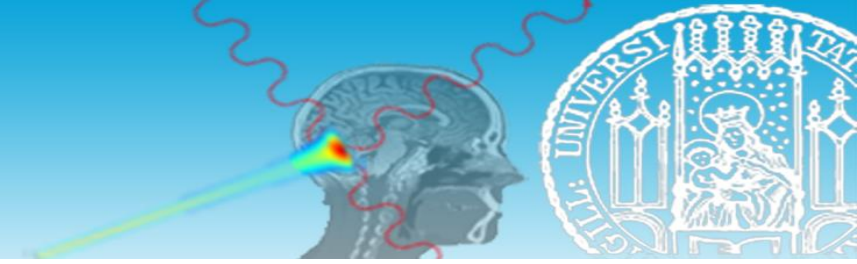

- Based on this convention, four Denavit–Hartenberg parameters (D-H parameters) are defined for each joint
 - I D-H parameter a_n (link length)
 - a_n is the absolute distance between Z_n and Z_{n+1}
 - II D-H parameter b_n (joint offset)
 - b_n is the distance along Z_n between X_{n-1} and X_n
 - III D-H parameter α_n (twist angle)
 - α_n is the angle between Z_n and Z_{n+1} across X_n (positive if counterclockwise)
 - IV D-H parameter ϑ_n (joint angle)
 - ϑ_n is the angle between X_{n-1} and X_n across Z_{n-1} (positive if counterclockwise)

The “forward” kinematics

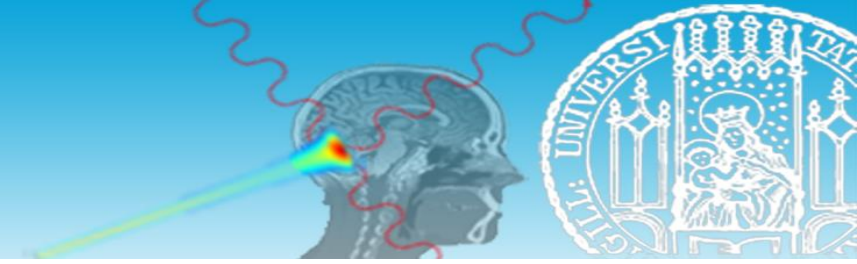

- Based on this convention, four Denavit–Hartenberg parameters (D-H parameters) are defined for each joint

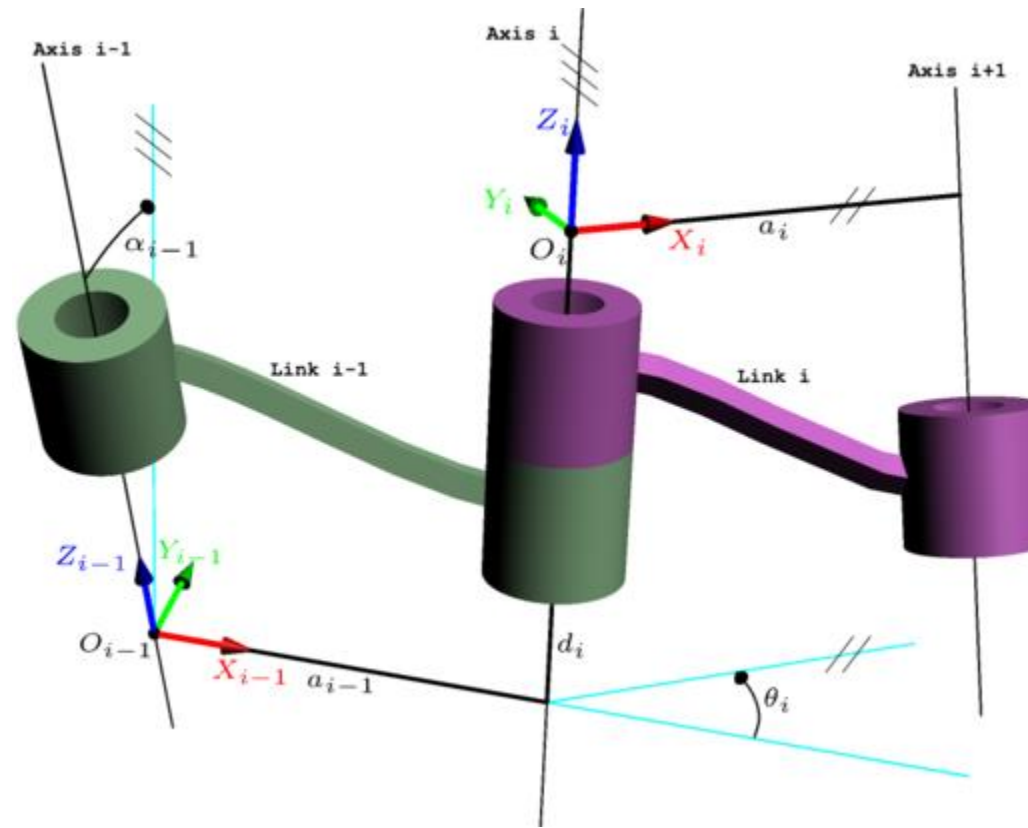

The “forward” kinematics

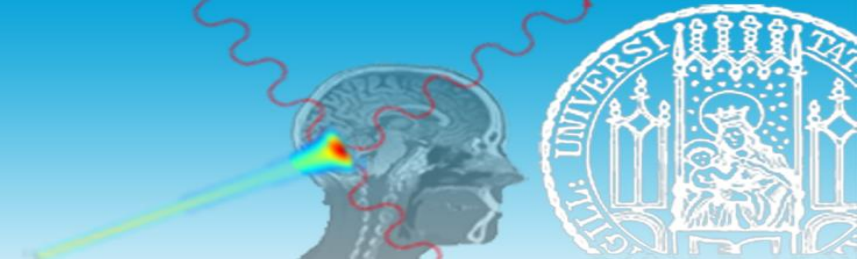

- The forward kinematics describe the transformation of the frame n with respect to the frame $n-1$ as a composition of rotations and translations in the **Denavit-Hartenberg matrix** (D-H matrix)

$${}^{n-1}T_n = R_X(\alpha_{n-1})D_X(a_{n-1})R_Z(\vartheta_n)D_Z(b_n)$$

- Translation along Z_n equal to b_n
- Rotation across Z_n equal to ϑ_n
- Translation along X_{n-1} equal to a_{n-1}
- Rotation across X_{n-1} equal to α_{n-1}

$${}^{n-1}T_n = \begin{bmatrix} \cos(\vartheta_n) & -\sin(\vartheta_n) & 0 & a_{n-1} \\ \sin(\vartheta_n)\cos(\alpha_{n-1}) & \cos(\vartheta_n)\cos(\alpha_{n-1}) & -\sin(\alpha_{n-1}) & -\sin(\alpha_{n-1})b_n \\ \sin(\vartheta_n)\sin(\alpha_{n-1}) & \cos(\vartheta_n)\sin(\alpha_{n-1}) & \cos(\alpha_{n-1}) & \cos(\alpha_{n-1})b_n \\ 0 & 0 & 0 & 1 \end{bmatrix}$$

Rotation matrix ${}^{n-1}R_n$

Translation vector ${}^{n-1}t_n$

The “forward” kinematics

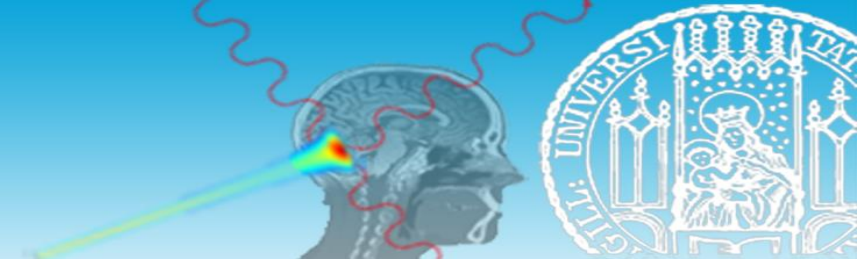

- The forward kinematics describe the transformation of the end-effector frame with respect to the base frame (i.e., frame 0) as a **composition of D-H matrixes**

$${}_{e-e}^0T = {}_1^0T \dots {}_{e-e}^{n-1}T = \prod {}_n^{n-1}T = \begin{bmatrix} e^{-e}R & e^{-e}t \\ 0 & 0 & 0 & 1 \end{bmatrix}$$

- The position of the end-effector in the base frame (i.e., frame 0) 0P is determined by the **matrix-vector product** of the **composed D-H matrix** with the position of the end-effector in the end-effector frame ${}^{e-e}P$
 - The frame at the end-effector can be arbitrarily defined

$${}^0P = {}_{e-e}^0T {}^{e-e}P$$

Descriptor of the
forward kinematics

The “forward” kinematics

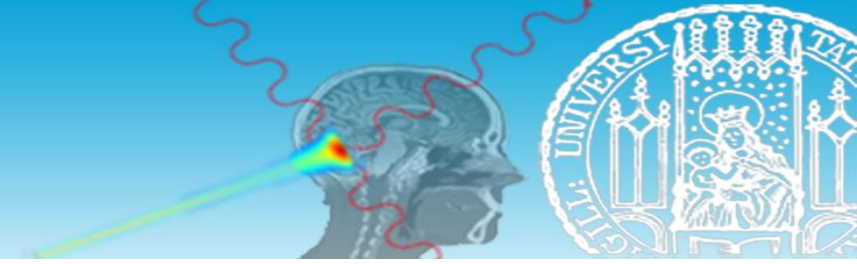

Four-joints and five links
planar robot

Link	b_n	ϑ_n	a_n	α_n
1	0	ϑ_1	a_1	0
2	0	ϑ_2	a_2	0
3	0	ϑ_3	a_3	0
4	0	ϑ_4	a_4	0

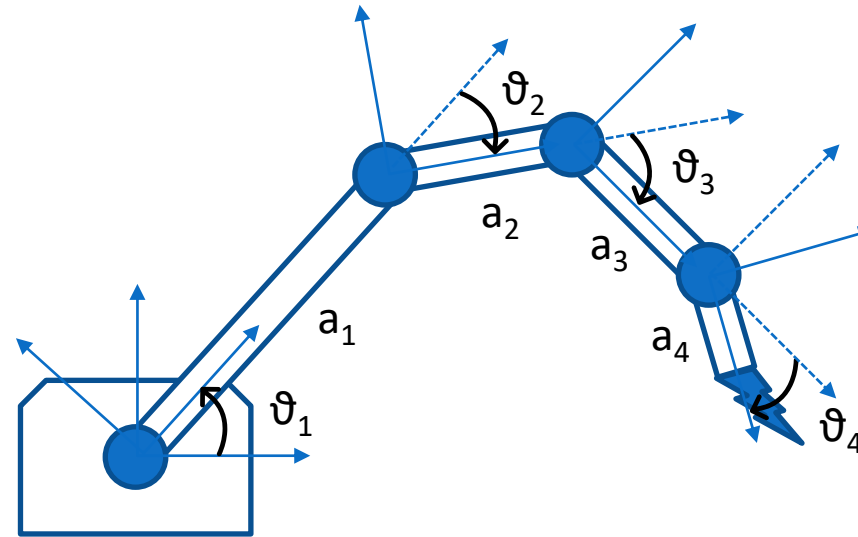

$${}^0T_4 = {}^0T_1 {}^1T_2 {}^2T_3 {}^3T_4$$

$${}^0T_4 = \begin{bmatrix} \cos(\vartheta_1) & -\sin(\vartheta_1) & 0 & 0 \\ \sin(\vartheta_1) & \cos(\vartheta_1) & 0 & 0 \\ 0 & 0 & 1 & 0 \\ 0 & 0 & 0 & 1 \end{bmatrix} \begin{bmatrix} \cos(\vartheta_2) & -\sin(\vartheta_2) & 0 & a_1 \\ \sin(\vartheta_2) & \cos(\vartheta_2) & 0 & 0 \\ 0 & 0 & 1 & 0 \\ 0 & 0 & 0 & 1 \end{bmatrix} \begin{bmatrix} \cos(\vartheta_3) & -\sin(\vartheta_3) & 0 & a_2 \\ \sin(\vartheta_3) & \cos(\vartheta_3) & 0 & 0 \\ 0 & 0 & 1 & 0 \\ 0 & 0 & 0 & 1 \end{bmatrix} \begin{bmatrix} \cos(\vartheta_4) & -\sin(\vartheta_4) & 0 & a_3 \\ \sin(\vartheta_4) & \cos(\vartheta_4) & 0 & 0 \\ 0 & 0 & 1 & 0 \\ 0 & 0 & 0 & 1 \end{bmatrix}$$

The “inverse” kinematics

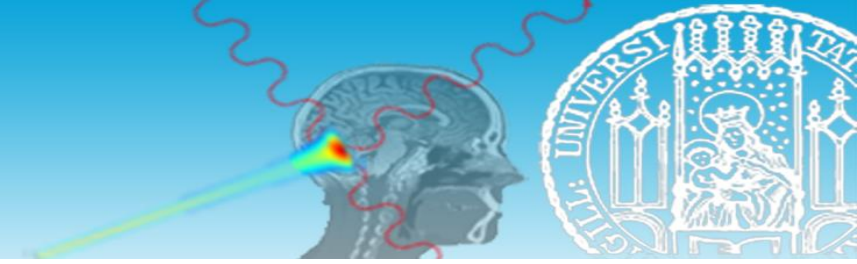

- *Finally, we have to know where the robot goes...*
- The inverse kinematics problem is about the knowledge of the **kinematic chain** of the mechanical system, given the desired position of the **end-effector** (i.e., the task)
- The solution of the inverse kinematics problem is defined within the **workspace** of the mechanical system
 - If the task is outside the workspace, the solution does not exist
 - If the solution exists, this can be single or multiple (infinite) depending on the DoF of the mechanical system

The “inverse” kinematics

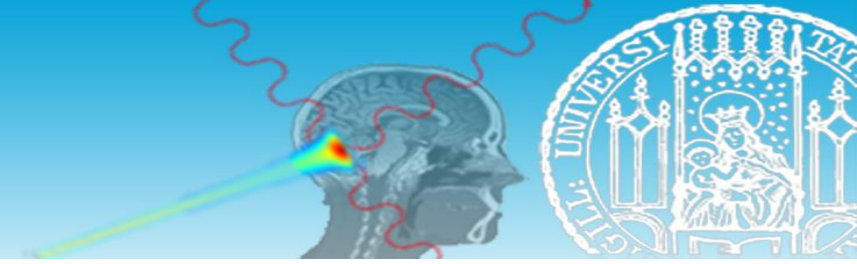

- The **number of unknowns** is defined by the DoF of the joints of the mechanical system
- The forward kinematics given by e_{-e}^0T provide **16** equations but 4 of them are trivial. Among the remaining 12 equations, 3 equations are relevant to the position-vector e_{-e}^0t and 9 equations are relevant to the rotation-matrix e_{-e}^0R . In the rotation-matrix only 3 equations are independent. The **number of equations** is therefore 6.
- The kinematic equations are **nonlinear** and **transcendental**, their solution is not always easy (or even possible) in a closed-form
 - For a 6-DoF robot, there are 6 equations and 6 unknowns. In this case, the analytical solution of the inverse kinematic problem is feasible



The “inverse” kinematics

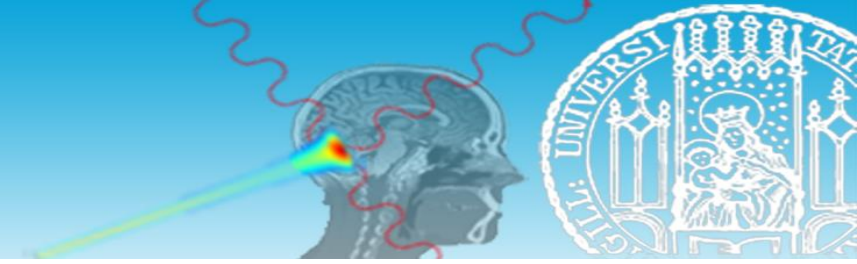

- Numerical methods (i.e., iterative optimization algorithm) based on approximation and derivatives of the forward-kinematics function for finding the local minimum
- If n the number of **joint variables**, the forward-kinematics function maps a point in the **joint space** to an end-effector position in the **workspace**

$$p(x): \mathbb{R}^n \rightarrow \mathbb{R}^3$$

- Given the initial position of the system $p_0 = p(x_0)$, the task is defined as $p_1 = p(x_0 + \Delta x)$
- Given the Jacobian of the forward-kinematics function $J_p(x_0)$, whose size is $6 \times n$, the Taylor series expansion of the forward-kinematics function, valid for small Δx , is calculated as:

$$p(x_1) \approx p(x_0) + J_p(x_0)\Delta x$$

- By calculating the (pseudo) inverse $J_p^{inv}(x_0)$, the updating step is defined as:

$$\Delta x \approx J_p^{inv}(x_0)\Delta p(x_0) \quad \text{with} \quad \Delta p = p(x_0 + \Delta x) - p(x_0), \text{ and thus} \quad \Delta x_{k+1} \approx J_p^{inv}(x_k)\Delta p_k$$

Robotics and artificial intelligence

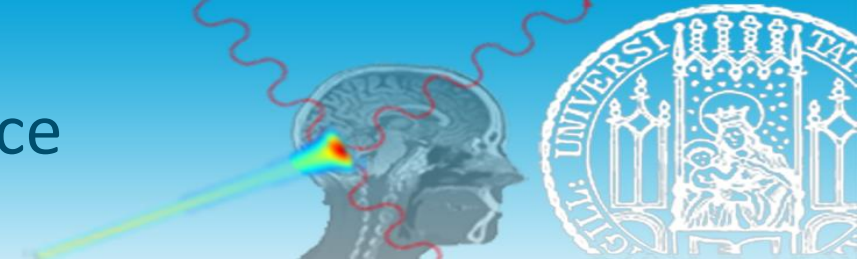

- The human body is a **mechanical system** made of joints and links that can implement a task
- The human senses define the **control system** that can provide information about the task
- The human brain is the **intelligence system** that can decide the task based on the sensor information

➔ artificial intelligence-driven robots

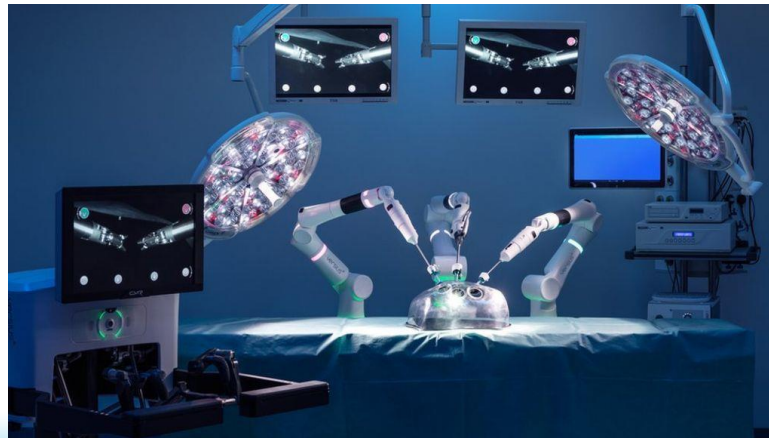
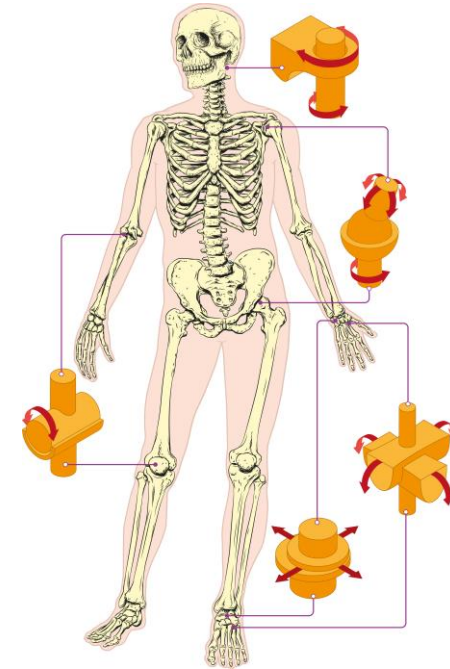

Robotic surgery

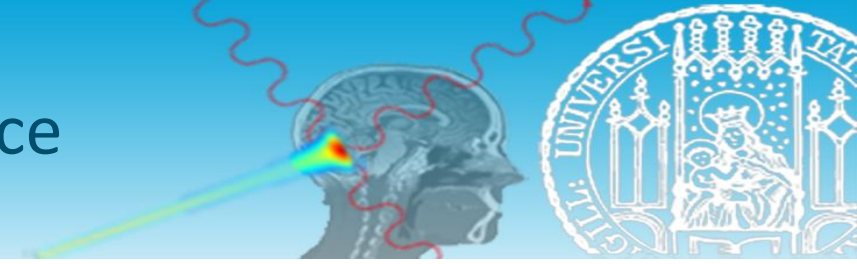

- In radiation oncology, the task is executed based on the **patient model** in the **treatment planning scenario**
- The task is adapted based on imaging and sensor systems for monitoring the **treatment delivery scenario**, thus adapting the *real* patient to the patient model (i.e., patient positioning) or vice versa, to adapt the patient model to the *real* patient (i.e., treatment adaptation and tumor tracking)
 - Correction models are defined (i.e., **anatomical correction models**, **external-internal correlation models**)
 - Model-free adaptive tasks based on AI

