TMP-TC2: Cosmology

Solutions to Problem Set 5

23, 24, 25 May 2023

1. Basics of Thermodynamics

Comment : A lot of the following solutions were created with the help of the book/lecture notes by Daniel Baumann. It is worth to take a look into it.

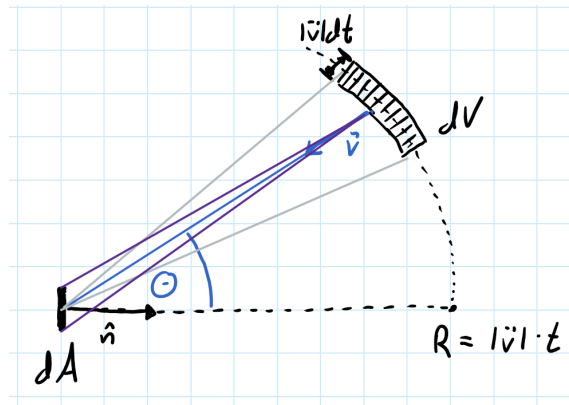

FIGURE 1 – Sketch for the derivation of the pressure.

1. The phase space density of a system is given by

$$\frac{g}{(2\pi)^3} f(k) \quad (1)$$

Therefore, the number of particles with energy E in a volume dV per unit volume in momentum space is

$$dN = \frac{g}{(2\pi)^3} f(k) dV \quad (2)$$

Now, take as a volume on small part of a spherical shell with radius $R = |\vec{v}|t$ and thickness $|\vec{v}|dt$ as given in figure 1 :

$$dV = d\phi d\theta \sin\theta R^2 |\vec{v}| dt \quad (3)$$

Only the particles that are directed to the area element dA will reach this area. So the number of particles coming from the volume dV and reaching the area dA is given by

$$dN_A = \frac{|\hat{v} \cdot \hat{n}| dA}{4\pi R^2} dN \quad (4)$$

For a better intuition you can have a look on the purple lines in figure 1. Assuming that the particles are reflected elastically, the momentum transfer

of one particle is $2|\vec{k} \cdot \hat{n}|$. The forces resulting from this momentum transfer is $\frac{2|\vec{k} \cdot \hat{n}|}{dt}$ and thus the pressure is

$$\begin{aligned} dp(|\vec{v}|) &= \int \frac{2|\vec{k} \cdot \hat{n}|}{dt dA} dN_A \\ &= \frac{g}{(2\pi)^3} f(k) \frac{k^2}{2\pi E} \int \cos^2 \theta \sin \theta d\theta d\phi \\ &= \frac{g}{(2\pi)^3} f(k) \frac{k^2}{3E} \end{aligned}$$

Integration over k gives the final result

$$p = \int \frac{g}{(2\pi)^3} f(k) \frac{k^2}{3E} dk \quad (5)$$

2. In the limit $m \ll T$ and $\mu \ll T$, the number density is given by

$$\begin{aligned} n &\approx \frac{g}{2\pi^2} \int_0^\infty dk \frac{k^2}{e^{\frac{k}{T}} + 1} \\ &= \frac{g}{2\pi^2} T^3 \int_0^\infty d\tilde{k} \frac{\tilde{k}^2}{e^{\tilde{k}} + 1} \\ &= \frac{g}{2\pi^2} T^3 \left(\int_0^\infty d\tilde{k} \frac{\tilde{k}^2}{e^{\tilde{k}} - 1} - \frac{1}{4} \int_0^\infty d(2\tilde{k}) \frac{(2\tilde{k})^2}{e^{2\tilde{k}} - 1} \right) \end{aligned}$$

where in the second equality we substituted $\tilde{k} = \frac{k}{T}$. Using the definition of the Riemann zeta function

$$\zeta(s) = \frac{1}{\Gamma(s)} \int_0^\infty \frac{x^{s-1}}{e^x - 1} dx \quad (6)$$

gives the result

$$n = \frac{g}{2\pi^2} T^3 \Gamma(3) \zeta(3) \left(1 - \frac{1}{4}\right) = \frac{3}{4\pi^2} \zeta(3) g T^3 \quad (7)$$

For the energy density we have in the numerator of the first integral a k^3 instead of k^2 . Applying the same steps gives at the end

$$\rho = \frac{g}{2\pi^2} T^4 \Gamma(4) \zeta(4) \left(1 - \frac{1}{8}\right) = \frac{7}{8} \frac{\pi^2}{30} g T^4 \quad (8)$$

where we used $\Gamma(4) = 6$ and $\zeta(4) = \frac{\pi^4}{90}$

3. The calculation here are very similar to the calculations of part 2. The only difference is that because of the minus sign in the denominator, the zeta function can be applied directly without splitting the fraction into two parts.
4. In this limit we have $E = |\vec{k}|$ and thus

$$\begin{aligned} \rho &= \frac{g}{(2\pi)^3} \int |\vec{k}| f(k) d^3k \\ p &= \frac{g}{(2\pi)^3} \int \frac{|\vec{k}|^2}{3|\vec{k}|} f(k) d^3k \end{aligned}$$

Therefore, $p = \frac{1}{3}\rho$.

5. Since we can assume that $\mu = -\bar{\mu}$, we obtain the expressions

$$n - \bar{n} = \frac{g}{2\pi^2} \int_0^\infty \left(\frac{1}{e^{\frac{k-\mu}{T}} + 1} - \frac{1}{e^{\frac{k+\mu}{T}} + 1} \right) k^2 dk \quad (9)$$

$$\rho + \bar{\rho} = \frac{g}{2\pi^2} \int_0^\infty \left(\frac{1}{e^{\frac{k-\mu}{T}} + 1} + \frac{1}{e^{\frac{k+\mu}{T}} + 1} \right) k^3 dk \quad (10)$$

With Mathematica we can find :

$$\int_0^\infty \left(\frac{1}{e^{x-a} + 1} - \frac{1}{e^{x+a} + 1} \right) x^2 dx = \frac{1}{3} a (a^2 + \pi^2)$$

$$\int_0^\infty \left(\frac{1}{e^{x-a} + 1} + \frac{1}{e^{x+a} + 1} \right) x^3 dx = \frac{1}{60} (15a^4 + 30a^2\pi^2 + 7\pi^4)$$

The Mathematica code is given in figure 2. Using this we have

```
In[1]:= $Assumptions = a ∈ Reals;
In[2]:= Integrate[x^2 * (1 / (Exp[(x - a)] + 1) - 1 / (Exp[(x + a)] + 1)), {x, 0, Infinity}]
Out[2]= 1/3 a (a^2 + π^2)

In[3]:= Integrate[x^3 * (1 / (Exp[(x - a)] + 1) + 1 / (Exp[(x + a)] + 1)), {x, 0, Infinity}]
Out[3]= -6 (PolyLog[4, -e^-a] + PolyLog[4, -e^a])

In[4]:= ResourceFunction["PolyLogSimplify"][-6 (PolyLog[4, -E^-a] + PolyLog[4, -E^a])] // FullSimplify
Out[4]= 1/60 (15 a^4 + 30 a^2 π^2 + 7 π^4)
```

FIGURE 2 – Mathematica Code for solving the relevant integrals.

$$n - \bar{n} = \frac{gT^3}{6\pi^2} \left(\pi^2 \left(\frac{\mu}{T} \right) + \left(\frac{\mu}{T} \right)^3 \right) \quad (11)$$

$$\rho + \bar{\rho} = \frac{7}{8} g \frac{\pi^2}{15} T^4 \left(1 + \frac{30}{7\pi^2} \left(\frac{\mu}{T} \right)^2 + \frac{15}{7\pi^4} \left(\frac{\mu}{T} \right)^4 \right) \quad (12)$$

6. In the non-relativistic limit $T \ll m$ and weakly interacting limit $T \ll m - \mu$ we can approximate the denominator by

$$e^{\frac{\sqrt{k^2+m^2}-\mu}{T}} \pm 1 \approx e^{\frac{\sqrt{k^2+m^2}-\mu}{T}}$$

So the number density is

$$n \approx \frac{g}{2\pi^2} \int_0^\infty dk k^2 e^{-\frac{\sqrt{k^2+m^2}-\mu}{T}} \quad (13)$$

We can see that the integrand is exponentially suppressed and so the main contribution to the integral comes from small k . Therefore, we can Taylor expand the square root $\sqrt{k^2 + m^2} \approx m + \frac{k^2}{2m}$. This gives the number density

$$n \approx \frac{g}{2\pi^2} e^{-\frac{m-\mu}{T}} \int_0^\infty dk k^2 e^{-\frac{k^2}{2mT}} = g \left(\frac{mT}{2\pi} \right)^{\frac{3}{2}} e^{-\frac{m-\mu}{T}} \quad (14)$$

2. Effective Number of Degrees of Freedom

First of all, we can find immediately

$$g_* = \sum_{\text{bosons}} g_i + \frac{7}{8} \sum_{\text{fermions}} g_i \quad (15)$$

Let us start to count the degrees of freedom coming from bosons. In the SM we have 3 bosons for weak interactions that are W^\pm and Z . All of them are massive and thus they give 9 degrees of freedom. Then we have one Higgs with 1 degree of freedom and the massless photon with 2 degrees of freedom. Furthermore, there are 8 gluons that are also massless. So they give 16 degrees of freedom. In total we obtain

$$g_{\text{bosons}} = 28 \quad (16)$$

In the fermion sector we have 3 neutrinos. Since fermions have two degrees of freedom (spin $\pm\frac{1}{2}$) they give in total 6 degrees of freedom. For the charged leptons we have another factor of 2 because there are also anti-particles. So they give 12 degrees of freedom. Finally, we have the 6 quarks with 3 color charges. Also here we have to count the anti-particles. This results in 72 degrees of freedom. In total we obtain

$$g_{\text{fermions}} = 90 \quad (17)$$

Using the formula from above results in

$$g_* = 106.75 \quad (18)$$

3. The Entropy of the Universe

1. For $|\mu_i| \ll T$, the fundamental equation of thermodynamics is $E = TS - pV$. Hence, the entropy density is

$$\begin{aligned} s &= \frac{S}{V} = \frac{\rho + p}{T} = \frac{4}{3} \frac{\rho}{T} \\ &= \frac{4}{3} \frac{\pi^2}{30} \left(\sum_{\text{bosons}} g_i + \frac{7}{8} \sum_{\text{fermions}} g_i \right) T^3 \\ &= \frac{2\pi^2}{45} g_* T^3 \end{aligned}$$

2. If we consider only photons, the degrees of freedom are $g = 2$. So the total entropy of the universe is given by

$$S = \frac{4}{3} \pi l_0^3 s = \frac{16}{135} \pi^3 l_0^3 T_0^3 \quad (19)$$

Restoring the constants gives

$$S = \frac{4}{3} \pi l_0^3 s = \frac{16}{135} \pi^3 l_0^3 T_0^3 \left(\frac{k_B}{\hbar c} \right)^3 k_B \sim 10^{65} \frac{J}{K} \quad (20)$$

3. Differentiate the Euler equation $U = TS - pV$ gives

$$dU = TdS + dTS - pdV - dpV$$

With $dU = TdS - pdV$ we obtain the Gibbs-Duhem relation

$$SdT = Vdp \quad (21)$$

With $s = \frac{p+\rho}{T}$ we get

$$\frac{\partial p}{\partial T} = \frac{p+\rho}{T} \quad (22)$$

For the differential of the entropy, we can write

$$dS = d(sV) = d\left(\frac{\rho+p}{T}V\right)$$

Now we can calculate that the entropy is conserved

$$\begin{aligned} \frac{dS}{dt} &= \frac{d}{dt} \left(\frac{\rho+p}{T} V \right) \\ &= \frac{V}{T} \left(\frac{d\rho}{dt} + \frac{1}{V} \frac{dV}{dt} \right) + \frac{V}{T} \left(\frac{dp}{dt} - \frac{\rho+p}{T} \frac{dT}{dt} \right) \end{aligned}$$

The first bracket is zero by the continuity equation $\dot{\rho} + 3H(\rho + p) = 0$ and the second bracket is zero by equation (22).

4. Relation between Time and Temperature

1. Due to entropy conservation we know that

$$S = sV \propto sa^3 = \text{const} \quad (23)$$

Using $s = \frac{2\pi^2}{45}g_*T^3$ we get

$$T \propto g_*^{-\frac{1}{3}} a^{-1} \quad (24)$$

2. In the relativistic case the Friedmann equation for a flat universe is

$$H^2 = \frac{8\pi G}{3}\rho_r \quad (25)$$

With $\rho_r = \frac{\pi^2}{30}g_*T^4$ and $M_{pl} = \frac{1}{\sqrt{G}}$ we obtain

$$H = \frac{\pi}{3} \sqrt{\frac{8\pi}{10}} \sqrt{g_*} \frac{1}{M_{pl}} T^2 \quad (26)$$

With $T = Ag_*^{-\frac{1}{3}}a^{-1}$ where A is a constant we have

$$\frac{1}{a} \frac{da}{dt} = \frac{\pi}{3} \sqrt{\frac{8\pi}{10}} \frac{\sqrt{g_*}}{M_{pl}} g_*^{-\frac{2}{3}} \frac{1}{a^2} A^2 \quad (27)$$

Integrating this equation and using $T = Ag_*^{-\frac{1}{3}}a^{-1}$ again gives at the end for the temperature

$$T = \sqrt{\frac{3}{2\pi}} \left(\frac{10}{8\pi}\right)^{\frac{1}{4}} g_*^{-\frac{1}{4}} \sqrt{\frac{M_{pl}}{t}} \quad (28)$$

$$\approx 0.55 g_*^{-\frac{1}{4}} \sqrt{\frac{M_{pl}}{t}} \quad (29)$$

$$\approx 1.56 g_*^{-\frac{1}{4}} \sqrt{\frac{1s}{t}} \text{MeV} \quad (30)$$